

International Astronomy and Astrophysics Competition

Qualification Round 2025

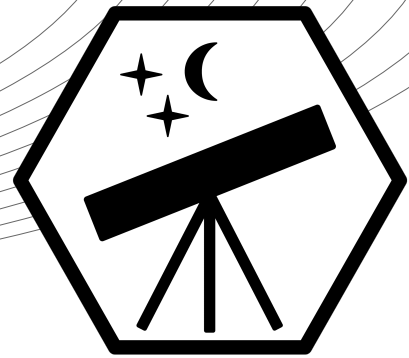

Problem A : Reflector Telescope (5 Points)

One of the most essential tools for astronomical research are telescopes. They allow us to see much further into space than possible with our eyes. Not only scientists but also astronomy enthusiasts from around the world use telescopes to explore the universe from home.

Find the correct names of the components tagged with the letters A to I in the sketch below.

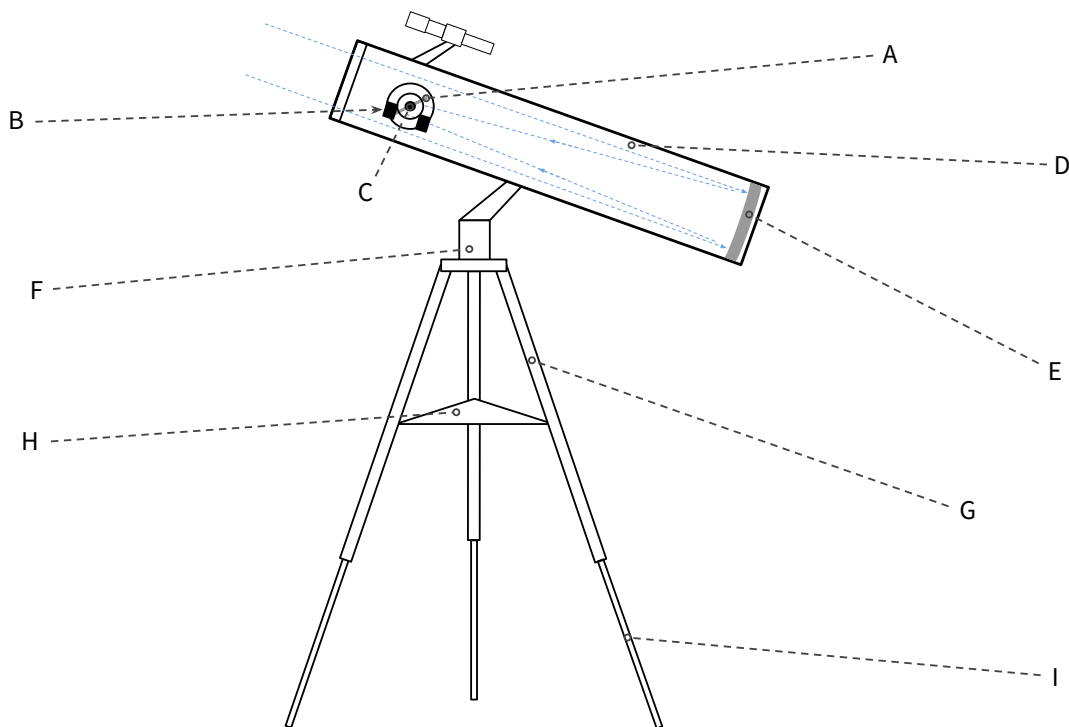

- | | | |
|-----------|-----------|-----------|
| (A) _____ | (B) _____ | (C) _____ |
| (D) _____ | (E) _____ | (F) _____ |
| (G) _____ | (H) _____ | (I) _____ |

Problem B : Distance to Alpha Centauri (5 Points)

Travelling to another star is a challenge because of the great distances between stars. The Alpha Centauri star system is the closest to the Sun, with its nearest member located 4.25 light-years away. The Sun and the Earth have a diameter of 1,400,000 km and 12,750 km, respectively, and they are on average 1 AU (astronomical unit; $\approx 1.496 \cdot 10^8$ km) far away from each other.

Assume that the Sun has a diameter of 22 cm, the size of a football. On this scale, what would be the size of the Earth, the distance between the Earth and the Sun, and to the nearest star?

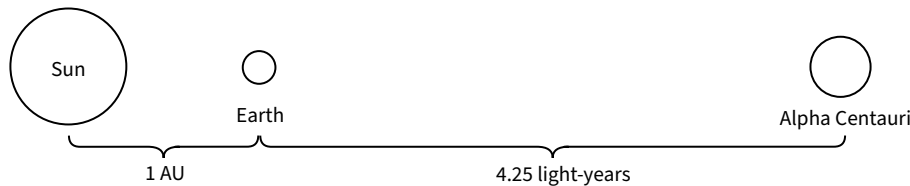

Problem C : Density of Planets (5 Points)

Knowing the density of planets is important for understanding their physical structure. It is possible to determine the average density ρ of a planet simply by measuring the gravitational acceleration g at the planet's surface and the planet's radius R .

(a) Show that the average density of a planet can be calculated using this equation:

$$\rho(g, R) = \frac{3}{4\gamma\pi} \cdot g \cdot \frac{1}{R}$$

(b) The gravitational acceleration on Earth is 9.81 m/s^2 . What is the Earth's average density?
(Note: $\gamma = 6.674 \cdot 10^{-11} \text{ m}^3/\text{kg/s}^2$ is the gravitational constant.)

Problem D : Cosmological Model (5 Points)

Cosmology studies the universe as a whole and how it develops over time: The *scale factor* $a(t)$ describes the change of distance in the universe. The *Hubble parameter* $H(t) = \dot{a}(t)/a(t)$ (where the dot represents the rate of change with respect to time) describes the rate at which the universe expands, and was measured to be around 72.6 km/s/Mpc using the James Webb Space Telescope in 2024. The *deceleration parameter* q describes the acceleration of the expansion:

$$q = - \left(1 + \frac{\dot{H}}{H^2} \right)$$

Assume a model with $a(t) = \lambda \cdot t^\beta$, where λ and β are real numbers. Knowing that the universe is around 13.7 billion years old, determine if the expansion is accelerating or decelerating.

Problem E : Comets (5 Points)

In January 2025, the comet C/2024 G3 passed by the Sun at a close distance of 0.09 AU. Because the comet was shining exceptionally bright, it is now called the *Great Comet of 2025*, and it is one of five comets in the last 100 years that can be observed with the naked eye during daylight. Other less bright comets pass by the Sun frequently and they are observable through telescopes.



Describe the materials of which a comet consist and explain why the bright tail forms.

Submission Information

You can write the solution by hand or type it on a computer. Please show your work! To qualify for the Pre-Final Round, you have to score at least 15/17/20 points as a Junior/Youth/Senior participant. You need to submit your solution online by *Friday, 4 July 2025, 23:59 UTC+0* at www.iaac.space/submission. If you have questions or comments, feel free to reach out to us via e-mail at any time: info@iaac.space. Good luck!